

**DE Kurzanleitung**  
**EN Quick Start Guide**

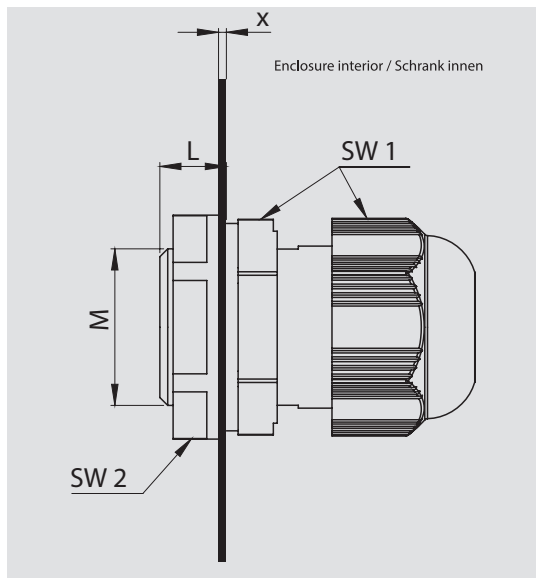

Art.-No.	thread		bore-Ø*	cable clamping area	wrench [mm]		tightening torque		weight
	size M [mm]	length L			SW1	SW2	lock nut	cap nut	
28410.0-00	M12 x 1,5	8 mm	12,3 mm	4 bis 7 mm	19	18	2 Nm	2 Nm	7 g
28411.0-00	M16 x 1,5	10 mm	16,3 mm	4 bis 7 mm	19	22	2 Nm	2 Nm	8 g
28412.0-00	M20 x 1,5	10 mm	20,3 mm	6 bis 11 mm	24	26	5 Nm	5 Nm	13 g

\*without thread

## Type DAK 284



03/2021

Technische Änderungen vorbehalten. Zum späteren Gebrauch aufbewahren.  
 Subject to change without prior notice. Store for use at a later date.

681233

**IP66/67**

